

PIPER

OWNER'S
HANDBOOK

1972
Tri-Pacer

PIPER AIRCRAFT CORP.

LOCK HAVEN, PENNSYLVANIA

OWNERS' HANDBOOK
FOR
OPERATION AND MAINTENANCE
OF
THE PIPER TRI-PACER
MODEL PA-22 AIRPLANE
1957

32-140

PIPER AIRCRAFT CORPORATION, LOCK HAVEN, PA.

TABLE OF CONTENTS

	Page
SECTION ONE	
Design Features	
I. Specifications	7
II. Power Plant and Propeller	8
III. Fuselage and Wings	9
IV. Landing Gear	10
V. Empennage	11
VI. Control System	11
VII. Fuel System	12
VIII. Electrical System	13
IX. Finish	17
X. Cabin Features	17
 SECTION TWO	
Operating Instructions	
I. Flight Procedure	23
1. Starting	23
2. Warm-up and Ground Check	23
3. Take-off, Climb, Stalls and Taxiing	24
4. Cruising	25
Cruise Power Settings	28
5. Approach and Landing	30
6. Hartzell Propeller Operation	31
7. Ground Handling and Mooring	32
8. Weight and Balance	32
 SECTION THREE	
General Maintenance	
I. Leveling and Rigging	33
II. Tire Inflation	35
III. Battery Service	35
IV. Brake Service	35
V. Landing Gear Service	37
VI. Fuel Requirements	42
VII. Care of Windshield and Windows	43
 SECTION FOUR	
Inspections	44
 SECTION FIVE	
Warranty	55

Additional copies of this manual may be purchased by writing to the SERVICE DEPARTMENT, PIPER AIRCRAFT CORPORATION, Lock Haven, Pennsylvania.

PICTURES AND ILLUSTRATIONS

	Page
Figure 1—Piper Tri-Pacer	6
Figure 2—Engine Installation	8
Figure 3—Landing Gear	10
Figure 4—Hydrasorb Installation	12
Figure 5—Control System—Ailerons and Elevators	14
Figure 6—Control System—Ailerons and Rudder Intercon- nection	15
Figure 7—Control System—Rudders and Flaps	16
Figure 8—Fuel System	18
Figure 9—Reserve Fuel System	19
Figure 10—Electrical System	20
Figure 11—Instrument Panel Arrangements	21
Figure 12—Fuel Consumption Chart	26
Figure 13—Altitude Performance Chart	27
Figure 14—Engine Power Chart	29
Figure 15—Battery Installation	36
Figure 16—Nose Wheel Installation	38
Figure 17—Nose Wheel Oleo Break-Down	40

FOREWORD

THIS manual covers operation and maintenance of the Piper Tri-Pacer, Model PA-22. The new Tri-Pacer provides more speed, comfort, reliability, economy of operation, and overall efficiency per unit of investment, than any four place personal plane heretofore produced in quantity. To obtain and maintain the maximum in utility and pleasure in the use of his airplane, the operator should carefully study the information provided for that purpose in this Handbook.

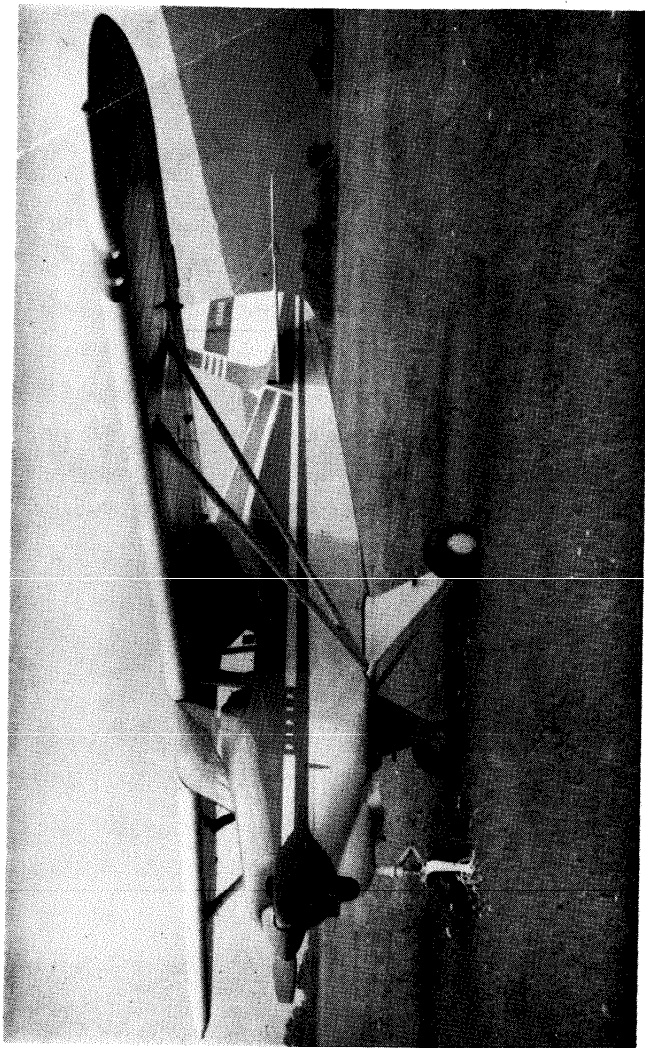

Figure 1

SECTION ONE

DESIGN FEATURES

I. SPECIFICATIONS:

	<i>PA-22 "150" Landplane</i>	<i>PA-22 "150" Seaplane</i>
Engine -----	Lyc. O-320	Lyc. O-320
HP and RPM -----	150 at 2700	150 at 2700
Gross Weight (lbs.) -----	2000	1950
Empty Weight (Standard) (lbs.) -----	1100	1280
Useful Load (lbs.) -----	900	670
Wing Span (ft.) -----	29.3	29.3
Wing Area (sq. ft.) -----	147.5	147.5
Length (ft.) -----	20.6	22
Height (in.) -----	100	103
Propeller Diameter (max. in.) -----	74.0	74.0
Power Loading -----	13.3	13
Wing Loading -----	13.5	13.2
Baggage Capacity -----	100	100
Fuel Capacity (Standard) -----	36	36
Fuel Capacity (Optional) -----	44	44
Tire Pressure (lbs.) -----	22 Main 15 Nose	
Top Speed (mph) -----	139	115
Cruising Speed (75% power at sea level MPH) -----	123	105
Optimum Cruising Speed (75% power, 7000' MPH) -----	132	110
Stalling Speed (MPH) -----	49*	58
Take-off Run (ft.) -----	1220*	---
Take-off over 50' barrier (ft.) -----	1600*	---
Landing Roll (ft.) -----	500*	---
Landing Distance over 50' barrier (ft.) -----	1280*	---
Best Rate of Climb Speed (MPH) -----	84	75
Rate of Climb (ft. per min.) -----	725	675
Best Angle of Climb Speed (MPH) -----	70	65
Best Angle of Climb (ratio) -----	1:11	1:9
Service Ceiling -----	15,000	13,850
Absolute Ceiling -----	17,500	16,200
Fuel Consumption (gal./hr.-75% power) -----	9	9
Cruising Range -----	492	420
Cruising Range (Optional Tank) -----	600	515

* Flaps Extended

Performance figures are for standard airplanes flown at gross weight under standard conditions at sea level.

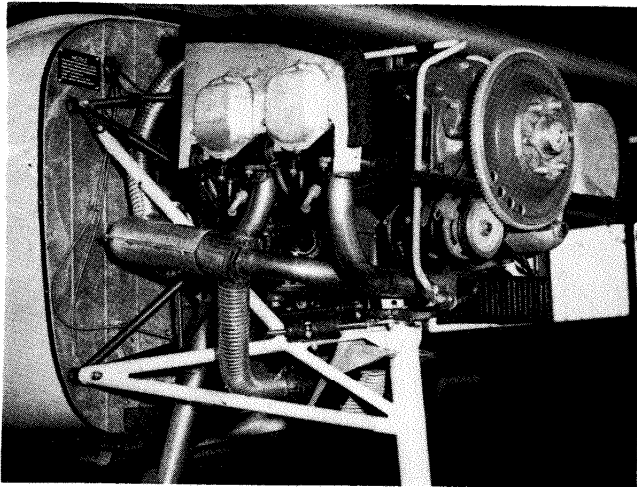

Figure 2

II. POWER PLANT AND PROPELLER:

The Tri-Pacer is powered by a Lycoming Model O-320 engine, rated at 150 horsepower at 2700 RPM for continuous operation. Details on the operation and maintenance of this engine are provided in the Engine Manual accompanying this Handbook.

A stainless steel cross-over exhaust system, incorporating an effective muffler, provides efficient exhaust elimination for the engine, as well as heat for the cabin and carburetor heating systems.

A thirteen plate oil radiator in the nose cowl assures adequate oil cooling under the most severe heat conditions. When outside temperatures drop below 40°F during cold weather operation, the oil radiator baffle supplied with each airplane should be installed. This baffle raises the indicated oil temperature about 30 to 40 degrees.

The carburetor air box on the Tri-Pacer is fitted with a quickly removable air filter. Removal of the filter is accomplished by detaching an access plate on the bottom cowl, then pulling the filter from the face of the air box. The filter should be cleaned regularly,

at daily intervals under very dusty conditions, and less frequently under less severe conditions, according to instructions printed on the filter frame.

A Sensenich metal propeller, design 74DM-59, with a 74" diameter and a 61" pitch is standard equipment on the PA-22.

Available as an option is the Hartzell constant speed propeller, Design HC82XG-2, with 72" diameter. This propeller is controlled by a Woodward Governor and Vernier type push-pull control.

III. FUSELAGE AND WINGS:

The fuselage frame of the Tri-Pacer is constructed of steel tubes welded together to form a rigid structure. A number of highly stressed members are of chromemolybdenum steel (4130). Other members are of 1025 steel.

Repairs to the fuselage can be made in the manner approved by the Civil Aeronautics Authority Manual No. 18, and repair facilities for this type of construction are available universally.

The fuselage is made corrosion resistant by the application of a coat of zinc chromate, followed by a sealer coat of nitrate dope. A third coat of dope-proof lacquer is sprayed on the fuselage members wherever fabrics comes in contact with the structure. If the airplane is to be used in salt water areas, the fuselage can be metallized prior to applying the zinc chromate and dope; at the same time the interior of the tubing is coated with linseed oil to prevent internal corrosion.

The wing framework consists of riveted aluminum ribs mounted on extruded aluminum spars with tubular drag and compression struts and high strength stainless steel drag wires. Aluminum sheet is used to form the leading edge and the aileron false spar. An ash wing tip bow provides a light tough member which can withstand considerable wing tip shock without failing.

The wings are attached to the fuselage at the wing hinge fittings on upper fuselage members, and by means of the lift struts which bolt to the lower fuselage members and to the wing spar fittings. The lift struts can be adjusted in length by turning in or out the forked fittings at the lower ends. This adjustment is used to set the rigging of the wings. Any lifting of the airplane at the struts should be done at the extreme end of the strut and not in the center, to prevent bending the struts.

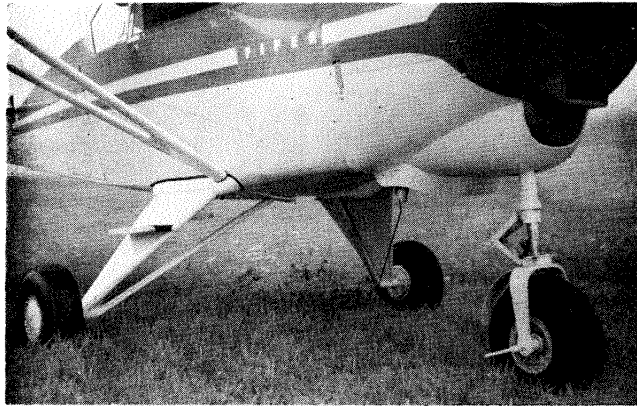

Figure 3

IV. LANDING GEAR AND BRAKES:

The PA-22 main gear incorporates Cleveland 600x6 wheels, Model C-38500-H, fitted with hydraulic brakes, Model C-2000H-7, and 4-ply 600x6 tires. The brakes are actuated by a hand brake control located under the center of the instrument panel. The brake handle is connected by a cable with a master cylinder which is mounted under the pilot's seat.

A parking brake valve is attached to the forward side of the firewall with the control located on the left side of the instrument sub-panel. In applying the parking brake, first pull the brake handle back, next pull out the parking brake control, then release the brake handle. To disengage the parking brake simply push in its control.

Also incorporated in the main gear are hydrasorb shock units, consisting of automotive type hydraulic shock absorbers combined with light shock cords.

The nose gear uses a rugged olco strut bolted to the engine mount at the firewall. The nose wheel is the same as the main wheels except for the absence of a brake drum, and is Model C-38501-H.

The nose wheel is steerable through a 40° arc by the rudder pedals which actuate steering rods attached to steering arms at the top of the nose wheel unit.

V. EMPENNAGE:

The units which make up the empennage are the Fin, Rudder, Stabilizers and Elevators. They are all constructed of tubular steel with steel channel ribs. The control surface hinges have bronze bushing inserts and should be oiled with light oil occasionally. Stainless steel tie rods brace the stabilizer to the fin and fuselage. The tail brace wires should not be used for lifting or handling the airplane.

Caution must be exercised in using the stabilizers for lifting or lowering the tail of the airplane. The stabilizer adjusting mechanism is easily damaged by application of excessive handling loads on the stabilizer.

On the PA-22, steering during ground handling should not be done with the rudder, which may become distorted if mishandled. A steering handle is provided with each airplane, anchored under the rear seat, and should be used for moving the plane on the ground.

VI. CONTROL SYSTEM (Figures 5, 6 and 7):

The Tri-Pacer is equipped with conventional dual wheel flight controls. The flap control handle is located between and ahead of the front seats. The flaps have three positions—Up, one-half down, and full down. The full flap position is used for maximum effect in landing and take-offs, while the half flap position is used when intermediate results are desired.

The stabilizer adjustment control is located overhead between the front seats and is connected to the stabilizer adjustment mechanism at the stabilizer by an endless cable. A permanently automatic tension adjustment, which consists of an idler pulley held in place near the rear main pulley by a tension spring, maintains correct tension on the stabilizer cable and prevents cable slippage. The system normally requires no attention except for lubrication and inspection.

In the control system of the Tri-Pacer, the rudder pedals are connected directly to the nose wheel for ground steering, and the aileron cables are interconnected with the rudder cables to provide automatically coordinated aileron and rudder controls for simplified handling in the air. The interconnection incorporates a spring, located behind the baggage compartment, and is arranged so that although in level flight a movement of the ailerons results in proper

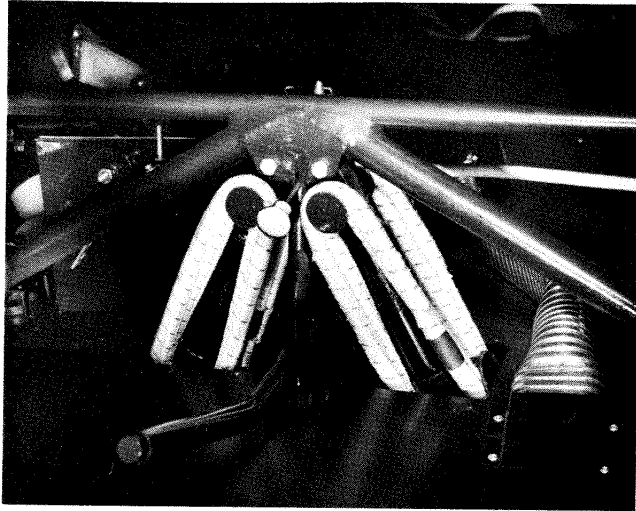

Figure 4

rudder action to give coordinated turns, still the controls can be crossed if desired to obtain slips or skids.

VII. FUEL SYSTEM (Figure 8):

Two eighteen gallon fuel tanks located in the wings provide fuel storage in the PA-22. Both tanks have outlet lines at the front and the rear, providing positive flow in all normal flight altitudes. The tanks are drained individually according to the position of the fuel selector valve on the left forward cabin wall.

The rear fuel line from the right tank has a low point under the right front seat at which point is located a quick drain gascolator. The drain in this gascolator, which should be checked frequently for water or sediment, is reached through an opening in the right landing gear belly fairing.

An electric fuel gauge for each tank is located on the right side of the instrument panel.

The main fuel strainer, through which all fuel going to the carburetor flows, is located on the lower left engine side of the firewall. It is provided with a quick drain and should be drained regularly.

Fuel screens are provided at tank outlets, in the strainer and at the carburetor.

The engine primer pump on the right side of the instrument panel takes fuel from the main gascolator and pumps it directly to all four cylinders of the engine. The primer must be locked in at all times except when in use, to prevent malfunctioning of the engine.

An idle cut-off is incorporated in the mixture control so that full extension of the control stops the flow of fuel at the carburetor. The cut-off should always be used to stop the engine.

An eight gallon reserve fuel tank which fits under the rear seat is available as optional equipment. The fuel from this tank is pumped by an electric pump under the co-pilot's seat to the fuel strainer for the right main tank. From the strainer the fuel passes up the main supply line to the right tank.

To use the reserve fuel supply, first use the right tank until it is at least half empty, preferably completely empty; this must be done while sufficient fuel remains in the left tank to continue to operate the engine until the right main supply is replenished. When the right tank is half full or less, switch the selector valve to left tank and pull the reserve fuel knob. The reserve fuel will then be pumped into the right tank, in a period of about 25 minutes. Then turn the reserve pump off.

Fuel should not be pumped from the reserve tank to the right main tank while the selector valve is at the right tank position.

VIII. ELECTRICAL SYSTEM:

The master switch for the electrical system is located on the master switch fuse box under the left side of the pilot's seat. In the "up" position of this switch the main fuse is engaged; the "down" position is for the spare fuse, and the central position is "off".

The starter button is located between the ignition switch and the carburetor heat control. The starter cannot be operated unless the master switch is on.

Circuit breakers for the radio, lights and generator are in a bracket under the left side of the instrument panel. These units auto-

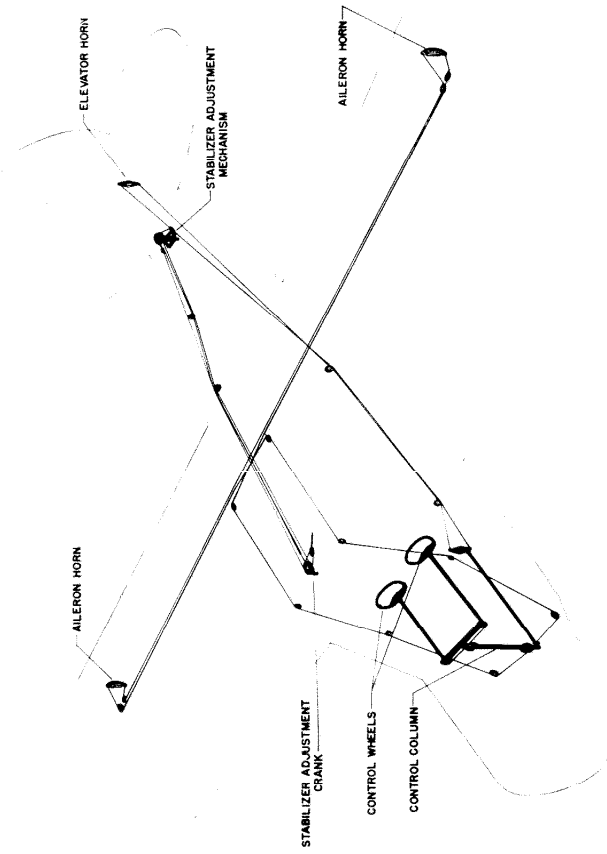

AILERON & ELEVATOR CONTROLS

Figure 5

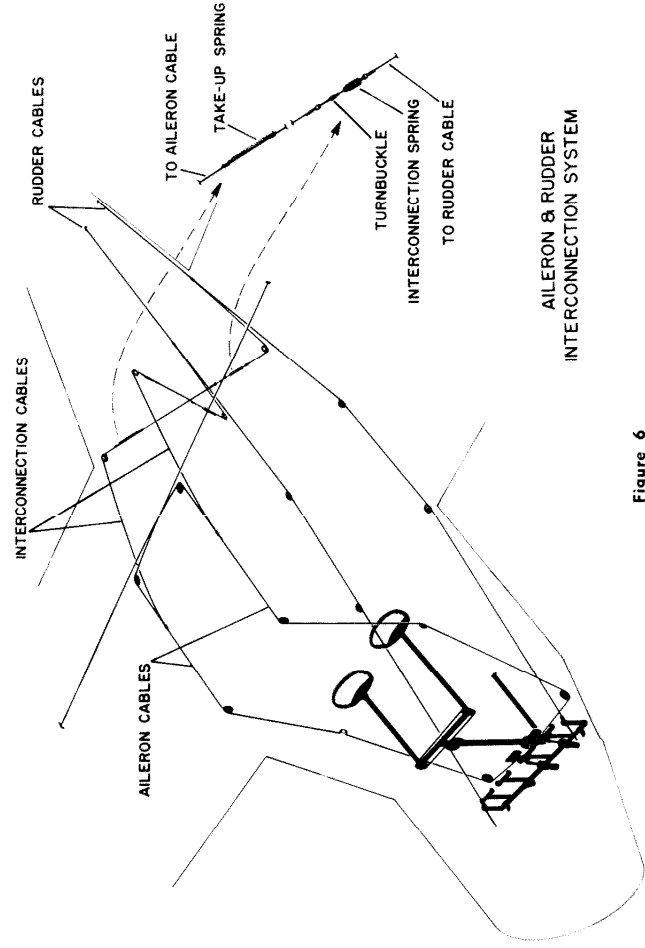

AILERON & RUDDER INTERCONNECTION SYSTEM

Figure 6

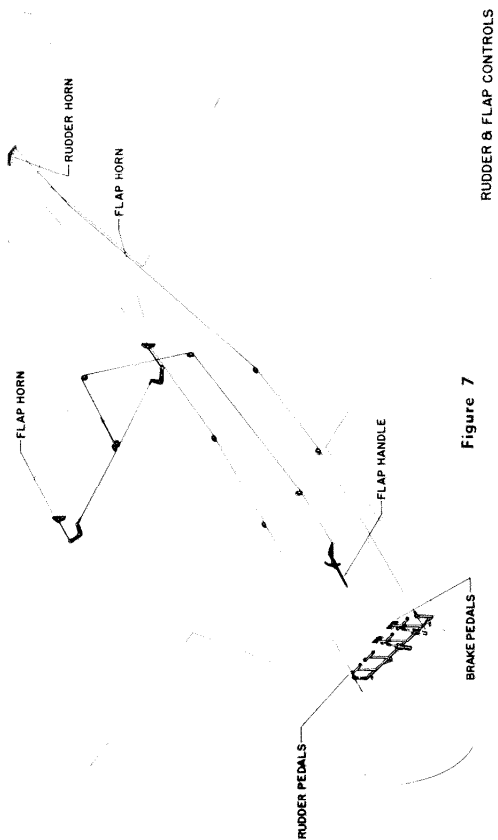

Figure 7

RUDDER & FLAP CONTROLS

matically break the electrical circuit if an overload is applied to the system, preventing damage to any electrical component. To reset the circuit breakers, simply push in the buttons. Continual popping out of a circuit breaker button indicates trouble in the electrical system and should be investigated immediately.

A 12-volt 33-ampere hour battery, enclosed in a stainless steel battery box, is mounted under the right front seat (See Section Three, III, Battery Service).

The position and panel lights are operated by a rheostat switch on the left side of the instrument panel. The position lights are turned on with the first movement of the knob; panel light intensity is increased by further rotation of the control. A dome light switch is incorporated in the speaker-dome light unit in the center of the cabin ceiling.

The landing light switch, on the lower left part of the instrument panel, controls two landing lights in the left wing. These lights are installed at different angles, the one directed downward to be used for taxiing and the upper beam for landing.

A voltage regulator, attached to the engine side of the firewall, is incorporated in the electrical system to maintain the required voltage of the battery.

IX. FINISH:

The Duraclad finish on the Tri-Pacer consists of fire resistant butyrate dope on the fabric surfaces, and enamel on all metal surfaces. Duraclad provides, in addition to the fire resisting qualities, a high-luster, more attractive finish which has a much longer life than earlier nitrate finishes.

All of the surfaces, inside and outside, are finished in Duraclad. This finish must not be covered over with any incompatible materials. The use of different material from those originally applied will damage the finish.

X. CABIN FEATURES:

The instrument panel on the PA-22 is designed to provide the utmost in flexibility of arrangement with a maximum of utility. All flight and engine instruments may be installed by removing the appropriate face plate. Easy access to the back of the instruments is available through a large removable panel on top of the instrument panel.

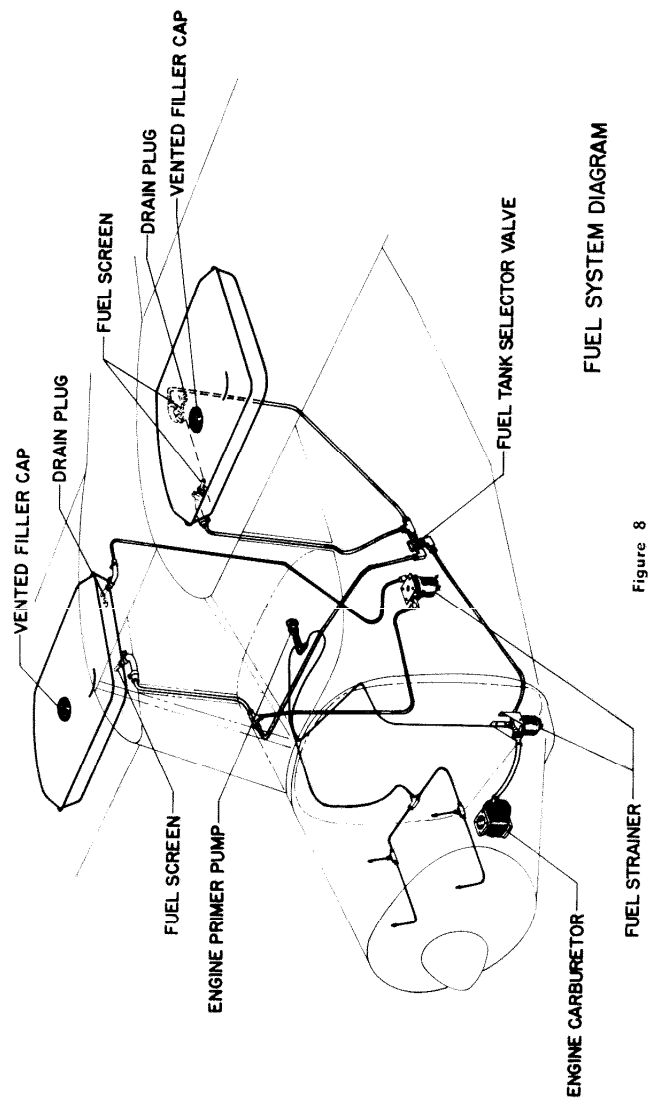

FUEL SYSTEM DIAGRAM

Figure 8

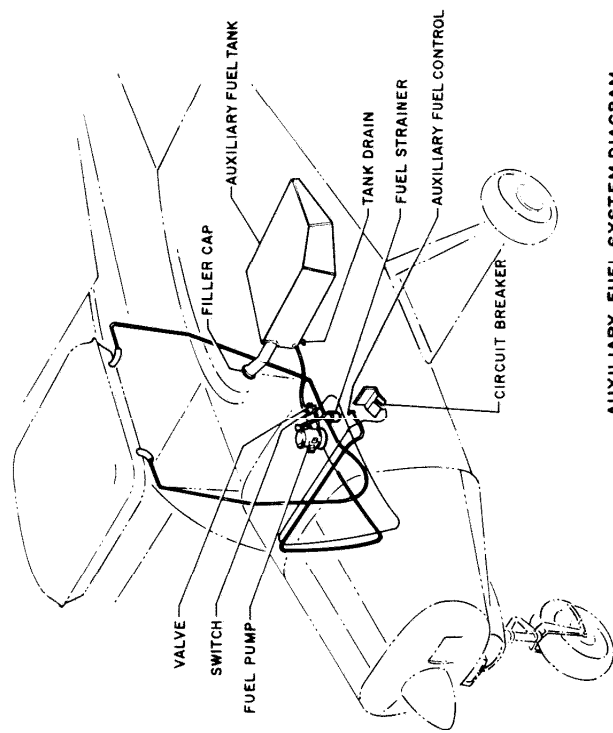

AUXILIARY FUEL SYSTEM DIAGRAM

Figure 9

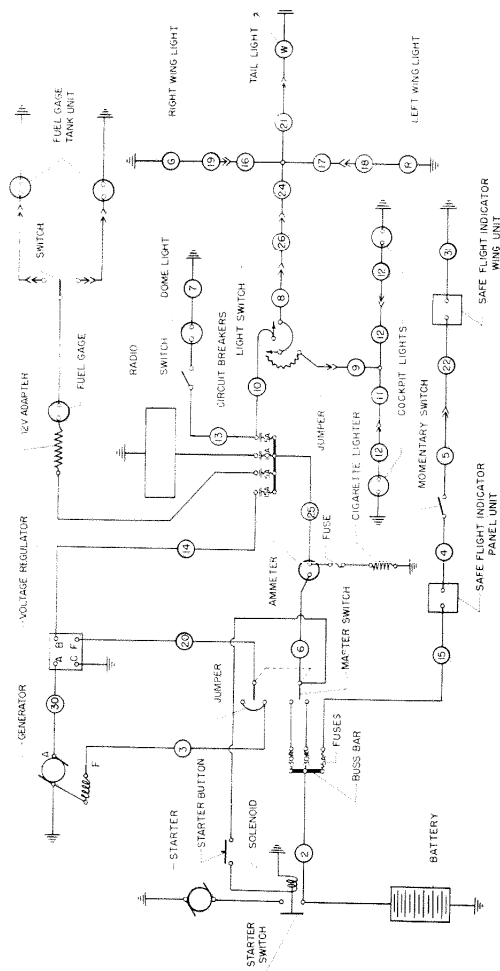

ELECTRICAL SYSTEM DIAGRAM
Figure 10

SECTION ONE

Face plates and insert panels are available for two panel arrangements. The standard panel consists of the required engine instruments plus airspeed, altimeter and compass. The standard arrangement also includes a large map compartment on the right side of the panel. The gyro panel accommodates the above mentioned instruments plus a manifold pressure gauge, artificial horizon, directional gyro, bank and turn indicator, rate of climb and a clock. Blank holes are available for the inclusion of radio navigation indicators or other instruments if desired.

Radio equipment is mounted in the center of the panel convenient to both pilots. Space is provided here for a variety of combinations of radio units (See Radio Manual for detailed instructions).

The separate front seats are individually adjustable through a 6" range. To adjust the seats, pull up on the seat adjustment handles, located under the front center corners of the seats, and move the seats to the desired position. In fixing the seat in any given position, be sure that the locking pin is securely engaged.

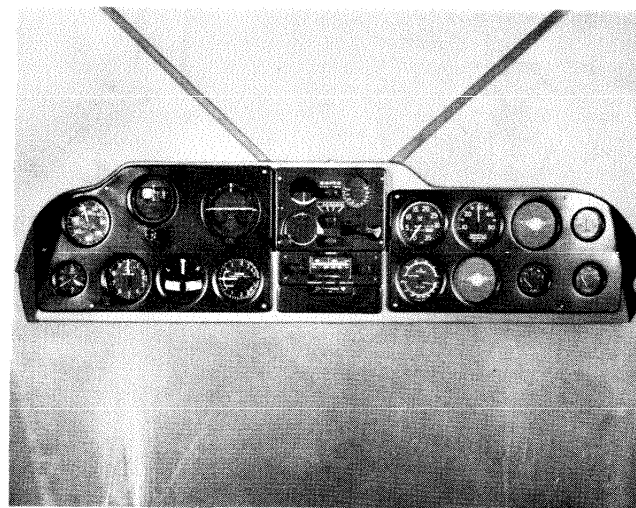

Figure 11

3. Take-off, Climb, Stalls and Taxiing:

Before take-off, it is very important that the fuel selector be checked to make sure it is on the proper tank. If the take-off is made with fuel flowing from a nearly empty tank, engine failure during or immediately following take-off may occur. In the event of engine failure after take-off, full power can be regained within a few seconds, and normally without loss of altitude, by switching rapidly to the opposite tank. In any case of engine failure which could possibly be caused by faulty fuel flow, always change to the other tank immediately.

The carburetor heat should be off for take-off, and the mixture rich unless field elevation requires leaning to obtain maximum RPM.

Take-off in the Tri-Pacer is accomplished as follows:

(a) Set stabilizer trim to approximately neutral with exact setting determined by the loading of the plane.

(b) Apply full throttle, allowing plane to maintain its level altitude until take-off speed (50-60 MPH) is approached, then ease back control wheel to obtain climbing altitude.

(c) For take-offs in heavy grass, snow, or in other speed retarding surfaces, drag on the landing gear can be reduced by raising the nose wheel off of the surface during the take-off run by applying back pressure on the control wheel shortly after the throttle is opened.

(d) The application of full flaps as take-off speed is approached, will reduce the take-off run about 20 percent. Flaps can be pulled down before the take-off run is started but will reduce the acceleration of the plane somewhat if kept down throughout the take-off.

(e) Crosswind take-offs in the Tri-Pacer should be made similarly to those in normal winds, with directional control maintained during and after the take-off roll by use of the rudder pedals. It may be desirable to hold the nose wheel on the ground somewhat longer than usual in strong crosswinds.

The best rate of climb airspeed at gross weight is 84 MPH. At lighter weights the best climbing airspeed is reduced somewhat. A climbing speed of 100 MPH is recommended for climbs to cruising altitudes, in order that a good forward speed may be maintained while reaching the desired altitude efficiently.

The gross weight power-off stalling speed with full flaps is 49 MPH; with flaps up the stalling speed increases about 4 MPH.

Taxiing: Visibility and control in taxiing the PA-22 is so improved that the usual tendency is to taxi at excessive speeds. The apparent speed of the plane on the ground is deceiving, so that on a hard surface a ground speed of 60 MPH can easily be reached at about 1500 RPM, with the pilot under the impression that he is traveling much more slowly. 1000 RPM will eventually give a ground speed of about 40 MPH, and even a high idling RPM may result in undesirably fast taxi speeds on occasion.

Considerable care should therefore be taken during taxiing to hold down engine RPM and to maintain reasonably low taxi speeds. High speed taxiing causes undue wear and strain on tires, brakes, and landing gear, and may result in damage from collision, upsetting, or other accidents. **DO NOT TAXI FAST.**

A limited amount of directional control during taxiing can be effected with the control wheel. If gradual turns are to be made during taxiing, or during the landing roll or take-off run, steering with the wheel may frequently be desirable.

4. Cruising:

The cruising speed of the PA-22 is determined by many factors including power setting, altitude, temperature, and equipment on the airplane such as antennas, venturi tubes and fenders.

The normal cruising power is 75% of the rated horsepower of the 150 horsepower engine, or 112.5 horsepower. The specification cruising speed at 75% of power at sea level under standard atmospheric conditions is 123 MPH. For altitude cruising speeds, see Figure 13, and for altitude power curves, see Figure 14.

Maintaining 75% of power at altitudes up to 7,000 feet, above which this power setting can no longer be obtained, results in an increase in true air speed of about 1.3 MPH per thousand feet of altitude over sea level. Indicated airspeed will normally decrease about 1 MPH per thousand feet if 75% power is maintained. If the True Air Speed at sea level at 75% of power is 123 MPH therefore, at 7,000 feet at 75% of power the True Air Speed will equal 132 MPH, while indicated air speed equals 116 MPH.

With a fixed pitch propeller 75% of power can be maintained at altitude by increasing the RPM as altitude is increased. The maximum continuous engine speed for all operations is 2700 RPM.

Fuel consumption during sea level cruising is given on Figure 12. The consumption is determined by the various flight conditions. At 75% of power at altitude, fuel consumption will be somewhat

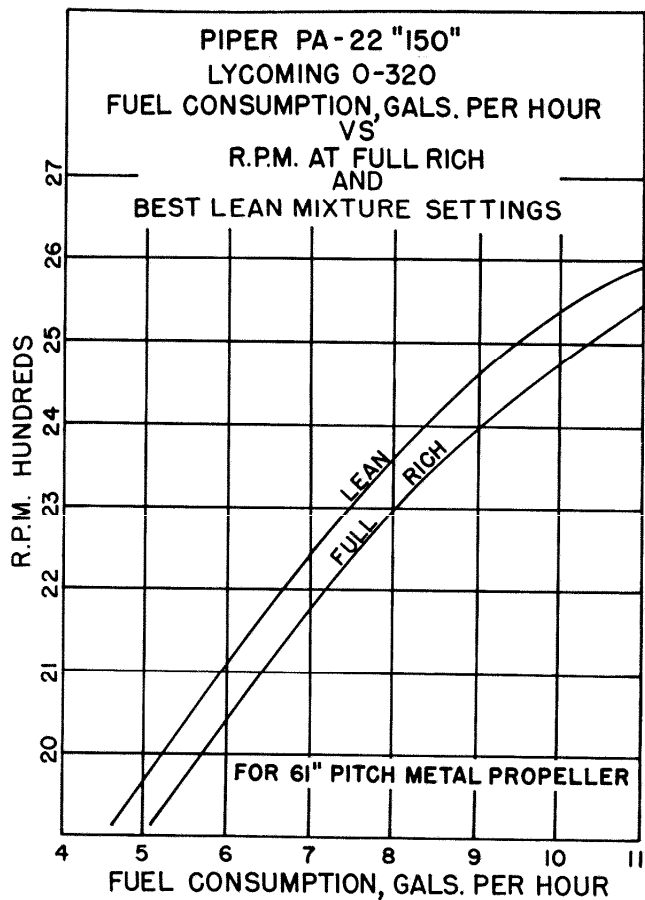

Figure 12

ALTITUDE VS TRUE AIRSPEED & RPM AT 75% POWER CRUISE

Model—PA-22 150

Mixture—Leaned to Maximum RPM

Propeller—Fixed Pitch Metal, 61"

Max. Level Flight RPM, Sea Level—2700 RPM

PROCEDURE FOR MAINTAINING 75% RATED POWER WITH INCREASED ALTITUDE

Starting at 2400 RPM at Sea Level, increase RPM by 25 per thousand feet of altitude. If Manifold Pressure is used, starting at 25" M.P. at Sea Level, allow M.P. to decrease 1/2" per thousand feet of increased altitude.

At 7000', RPM will approximate 2550, M.P. 22" Hg. and T.A.S. 132 MPH.

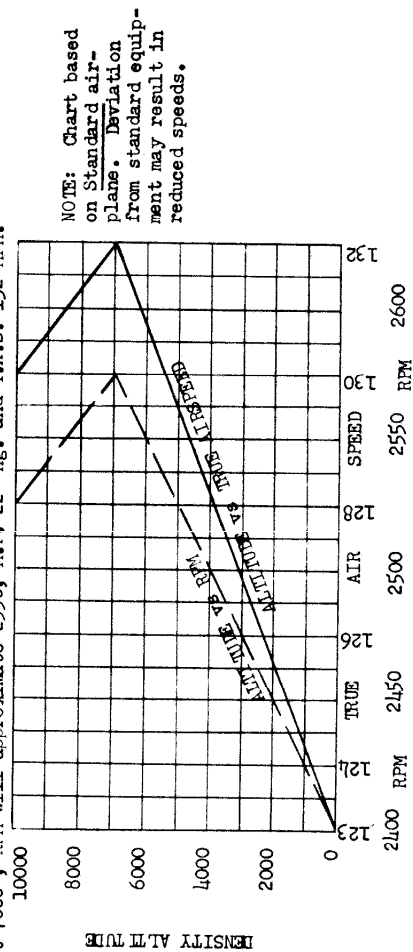

Figure 13

**CRUISE POWER SETTINGS
PIPER PA-22 "150" WITH HARTZELL CONTROLLABLE PROPELLER**

55% (82.5 HP) 65% (97.5 HP) 75% (112.5 HP)
 7 Gals./Hr. 8 Gals./Hr. 9 Gals./Hr.

STD. ALTITUDE	7 Gals./Hr.			8 Gals./Hr.			9 Gals./Hr.			
	RPM	2100	2250	RPM	2100	2250	RPM	2100	2250	2400
Sea Level	22.5	21.2	20.2	23.7	22.5	21.2	24.7	23.7	22.5	21.2
2000'	22	20.7	19.7	23.2	22	20.7	24.2	23.2	22	20.7
4000'	21.5	20.2	19.2	22.7	21.5	20.2	23.7	22.7	21.5	20.2
6000'	21	19.7	18.7	22.2	21.2	19.7	23.2	22.2	21.2	19.7
8000'	20.5	19.2	18.2	—	20.8	19.2	—	—	—	—
10000'	20	18.7	17.7	—	20.4	18.7	—	—	—	—
12000'	19.5	18.2	17.2	—	—	18.2	—	—	—	—

Power settings are at standard temperatures for the given altitude. Fuel consumption figures are for operation with mixture leaned.

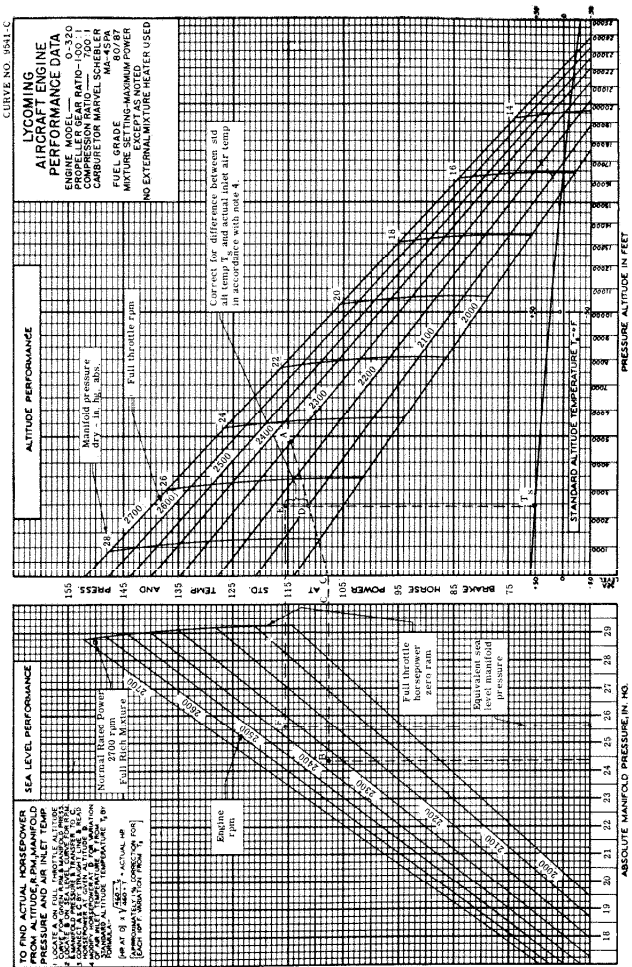

Figure 14

higher than at that power setting at sea level, even with the mixture properly leaned.

Correct use of the mixture control will reduce fuel consumption very appreciably. The mixture should be leaned during cruising flight at all times over 5000 feet and at lower altitudes at the owner's discretion. The mixture should also be leaned at full throttle at any time at which an increase in RPM can be obtained.

To adjust the mixture properly, pull out the control slowly until a decrease in RPM is noted; then push the control forward just enough to regain the lost RPM.

A cruise-stop is incorporated in the throttle mechanism of each PA-22. This stop is set to give 75% of power at low altitudes under normal conditions. If a higher or lower power setting is desired, it can be obtained by installing or removing small spacers in the throttle lock according to instructions attached to the throttle.

The cruise-stop is intended to give consistent power settings at lower altitudes without reference to the tachometer. It also provides a more or less fixed RPM, the variance of which indicates the presence of ice or other causes of malfunction.

To determine the proper cruising RPM for 75% of power, fly the aircraft as near sea level as practicable at full throttle until maximum speed is reached. Note the RPM at top speed, level flight. Then reduce the maximum RPM by 10% and cruise at 90% of full RPM. The correct cruising RPM, which is the proper setting for the cruise-stop, will give specification cruising airspeed and fuel consumption.

The continuous use of carburetor heat during cruising flight increases fuel consumption. Unless icing conditions in the carburetor are severe, do not cruise with the carburetor heat on. Apply full carburetor heat only for a few seconds at intervals determined by icing severity.

5. Approach and Landing:

The approach technique is as follows: Trim the plane to a 75-80 MPH glide, after flaps have been lowered at a speed of 95 MPH or less. Mixture should be full rich, fuel on proper tank, and carburetor heat off unless carburetor icing conditions prevail. Reduce the speed during the flareout, and touch the ground in a standard three point position approximately at stalling speed (50-60 MPH).

On the Tri-Pacer, the control wheel should be held back far enough to keep the plane in a nose high altitude as long as possible.

This shortens the landing run by producing maximum drag on the wings. As the plane slows down, allow the nose wheel to drop to the ground and apply brakes.

In high wind conditions, particularly in strong crosswinds, it may be desirable to approach the ground in a more nearly level altitude at an airspeed which assures ample controllability regardless of gusts. In this case the ground can be contacted at airspeeds appreciably higher than in normal landings, and the airplane held in a level altitude at all times on the ground to reduce wind effect. It is always best to contact the ground at the minimum practicable speed consistent with landing conditions.

Crosswind landings in a PA-22 should be approached with drift being compensated for by holding the windward wing down or by crabbing into the wind. The airplane should be straightened out the instant before ground contact, and then controlled on the ground with the steerable nose wheel which should be held on the ground with forward control wheel pressure.

6. Hartzell Propeller Operation:

The Hartzell constant speed propeller installation offers improved take-off and climb performance and provides for more efficient engine operation in some cruising conditions. The propeller control is of the Vernier push-pull type, fine variations in r. p. m. being obtained by rotating the control and large changes by depressing the button on the face of the control and moving the knob in or out.

Individual techniques in operation of the constant speed propeller are quickly developed; however, the following operating procedures are offered as a guide. When decreasing power, always decrease manifold pressure first, r. p. m. second, conversely when increasing power, increase r. p. m. first, manifold pressure second. When operating at 2300 r. p. m. or less do not use more than 25" H. G.

For take-off, full r. p. m. and full throttle are used. Shortly after take-off when best climb speed is reached, the throttle may be reduced to 25" H. G. and the r. p. m. to 2400. During the climb to cruising altitude, the manifold pressure should be maintained by increasing the throttle periodically. A cruise power setting table is included in this section of the manual.

7. Ground Handling and Mooring:

Moving of the PA-22 is most easily accomplished with the nose wheel steering handle provided with each plane.

Tie-downs are provided at the wing-strut intersections and the tail skid should be used for tail anchorage.

In windy conditions the flaps should be lowered fully and the control wheel restrained with a safety belt to prevent the control surfaces from becoming damaged.

8. Weight and Balance:

For weight and balance data see the weight and balance form supplied with each airplane, which gives the exact weight of the airplane and permissible center of gravity conditions.

SECTION THREE

GENERAL MAINTENANCE

I. LEVELING AND RIGGING:

A. Leveling:

(1) Place adjustable jacks or blocks under the axle extension so that the jacks or blocks do not touch the brake lines or connections. Raise each wheel by pushing up on the lift struts on one side and pulling down on the opposite side. All lifting or pulling pressure must be applied as near to the wing attachment points as possible so as to be sure that the lift struts will not be bowed.

To level the airplane laterally, remove lower right wing root fairing, drop a plumb bob on a string from the hole located on the side of the upper door frame member approximately $5\frac{3}{4}$ inches aft of the front door frame member, to the center punch mark located on the seat front tube just inside the door. Adjust the jacks or blocks until the plumb bob centers over the mark.

The airplane is longitudinally leveled either by raising the nose wheel with blocks or lowering it by releasing air from the tire until the plumb bob is centered.

(2) Dihedral Angle—Stretch a length of string from wing tip to wing tip along the top of the wing at the front spar location. Measure down from the string to the top of the fuselage front wing hinge fittings a distance of $4\frac{7}{8}$ inches. Adjust the front lift strut fork fittings in or out to produce this dimension.

To check for equal dihedral in each wing, use a 30-inch level held spanwise against the underside of the wing at the front spar location. Note the amount of off level on one wing and see if the other wing has the same amount of off level. Adjust the front lift strut forks in on one side and out on the other to get the same amount of off level in both wings. Check the $4\frac{7}{8}$ -inch dimension after this adjustment to see that it has not been effected by the equalizing adjustment.

(3) Wash-Out—Place a $1\frac{3}{8}$ -inch block under the wing at the rear spar location at the outboard aileron rib. Place a 30-inch level chord-wise across this block with the front end of the level at the front spar location. The bubble will center if the wing has the proper $2\frac{1}{2}$ degree washout. Adjust the rear lift strut forks in or out to bring the bubble to center.

(4) Tail Assembly—Level the stabilizers at the rear spar with the airplane in level position. Adjustment is accomplished by the

tightening and loosening of the tail brace wires. Take up as many turns as the opposite wires are let out, to keep the same tension on the wires. Do not scratch or mar the wires with pliers or wrenches as this may cause the wires to fracture. Plumb the rudder hinge line. Slight adjustments can be accomplished by firmly pushing against the fin rear spar in that direction required to bring the hinges in line. The streamline tail braces wires should be lined up with the air-stream or a whistling noise will result.

(5) Control Surface Travels:

Aileron	-----	15° up	15° down
Elevator	-----	24° up	12° down
Rudder	-----	16° R	16° L
Stabilizer	-----	1° up	6½° down
Flaps	-----	40° down	

B. PA-22 Control System Rigging:

In the control system of the Tri-Pacer to provide automatically coordinated aileron and rudder controls for simplified air control, and to increase stability in flight, the aileron control cables are connected to the rudder cables by means of an interconnecting cable. The interconnection incorporates a spring and is arranged so that although in level flight a movement of the ailerons results in the proper rudder action to give coordinated turns, still the controls can be crossed if desired to obtain slips or skids.

In rigging the control system of the PA-22, this procedure should be followed:

1. Center the nose wheel, rudder pedals, rudder and ailerons with the interconnecting cables slack at turnbuckles, located behind the baggage compartment.
2. Check the airplane in flight for proper trim with the interconnecting cables slack.
3. During the flight check, if ailerons do not line up with the flap trailing edges equally, adjust the aileron tab to obtain proper aileron position.
4. If airplane is wing heavy with ailerons in proper position, adjust the rear strut fork on the wing heavy side inward to obtain correct trim. Each ten degrees of wing heaviness in flight requires approximately one turn of the strut fitting.

5. If the airplane skids in flight when the wings are level, it is out of rig directionally. To correct this condition, bend the leading edge of the fin in the direction towards which the airplane skids. Be careful not to depress the fin far enough to cause fabric wrinkles.

6. After the plane is trimmed properly directionally and laterally, tighten the interconnecting cables with the coil springs just beginning to become extended.

7. Check the trim of the plane in flight again to see that trim has not been affected by step 6, and to see that interconnecting cables are at correct tension to give properly coordinated controls. If the interconnecting cable tension is excessive, too much rudder movement will result from aileron movement, causing a skid. If the cables are not tight enough, the rudder will not move far enough when the control wheel is rotated to give coordinated turns. Proper tension will give coordinated turns at cruising speeds when either the wheel or the rudder controls are moved.

II. TIRE INFLATION:

For maximum service from the tires, keep the PA-22 main wheels at 22 lbs., and the nose wheel at 15 lbs. Reverse the tires on the wheels, if necessary, to produce even wear.

III. BATTERY SERVICE:

A Reading 12 volt, 33 ampere hour battery is installed under the right front seat in a stainless steel battery box. Access to the battery is obtained by removing the seat.

The battery should be checked frequently for proper fluid level, but must not be filled above the baffle plates. All connections must be clean and tight.

If the battery is not up to proper charge, recharge starting with a charging rate of 4 amps and finishing with 2 amps. If a quick charge is desired for the battery master switch must be off during charging.

IV. BRAKE SERVICE:

The brake master cylinder in the Tri-Pacer is a dependable diaphragm type requiring a minimum of servicing. It can be refilled when necessary at the filler plug on top of the cylinder. Univis No. 40 hydraulic oil is used here as in the other hydraulic units in the PA-22.

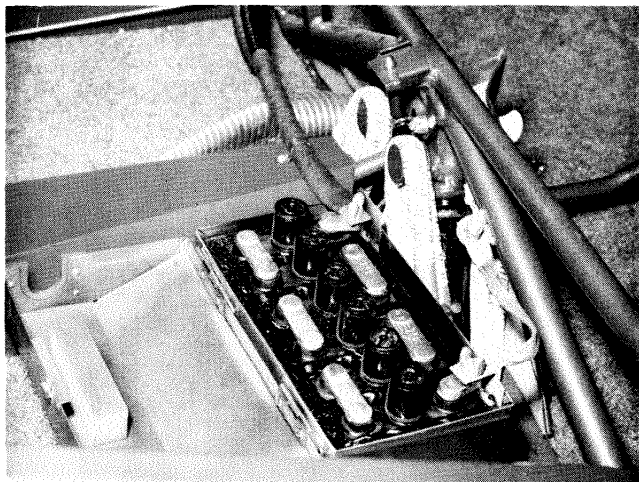

Figure 15

To refill the cylinder (1) apply hand brake hard, forcing fluid into brake lines and shoes; (2) apply parking brake to lock fluid in position; (3) remove filler plug and add oil until cylinder is full; (4) replace plug, release brakes, and check wheels to see that they still turn freely—if not, release a small amount of fluid at the brake bleeder valve at the wheel, and recheck.

To fill the brake system with fluid initially, (1) loosen brake bleeder valves at wheels; (2) add fluid at cylinder until fluid flows from bleeders, then tighten valves; (3) install plug at cylinder; (4) apply brake and parking brake to force fluid downward in system; (5) open bleeder valves to allow air to escape at wheels; (6) continue to add fluid at cylinder and bleed air from valve until air is eliminated, then refill cylinder and check wheels for free movement.

The position of the hand brake control should be such that hand movement in the cockpit is nearly horizontal rather than upwards. An adjustment of the cable length is provided at the cylinder to position the brake handle. Usually an excessive travel of the brake handle indicates that brake fluid needs replenishing.

The brakes can be adjusted for clearance between the brake shoes and the drums by rotating two cams located on the brake flange as follows:

- (a) Place the axle of the wheel to be adjusted on a jack or block so that the wheel turns freely.
- (b) Loosen the lock nuts which lock cams in position.
- (c) Rotate the cams until the wheel can just be turned without brake friction.
- (d) Tighten the lock nuts, making sure that the cams do not change position while being locked in place.

The main wheels are removed by detaching hub caps and dust caps, removing the axle nuts, and sliding the wheel from the axle. To remove the nose wheel, remove one axle nut, slide the axle through the nose wheel fork, and drop the wheel from its fork. In reinstalling the nose wheel, the axle nuts should not be drawn up tight enough to bind wheel bearings.

Tires (600x6 balanced four ply on all wheels) are dismantled from wheels by (1) deflating tubes; (2) removing wheel from axle; (3) taking stop nuts from wheel through-bolts; (4) withdrawing the two halves of wheel from tire.

V. LANDING GEAR SERVICE:

The Hydrasorb units on the PA-22 incorporate a hydraulic shock absorber unit and two 8"x $\frac{5}{8}$ " shock cords. The units can be removed for servicing as follows: (1) raise the airplane until the main wheels do not touch; (2) tilt the front seat back; (3) remove the upper Hydrasorb attaching bolts and allow the gear to drop down; (4) detach lower end of units.

The shock cords on the Hydrasorb units should be replaced if they become weakened. The hydraulic units cannot be repaired and must also be replaced when worn.

The nose wheel mounting on the PA-22 is readily removed for service as follows:

1. Push tail of plane down until tail skid rests on ground. Hold tail in this position with tie down or by resting a load on the stabilizer. (It is suggested that sand bags be laid on a plywood sheet on the inboard part of the stabilizers. Care must be taken not to damage the stabilizer adjustment mechanism or the fabric.) This raises nose wheel from the ground so that it can be removed.

2. Remove bottom cowl.

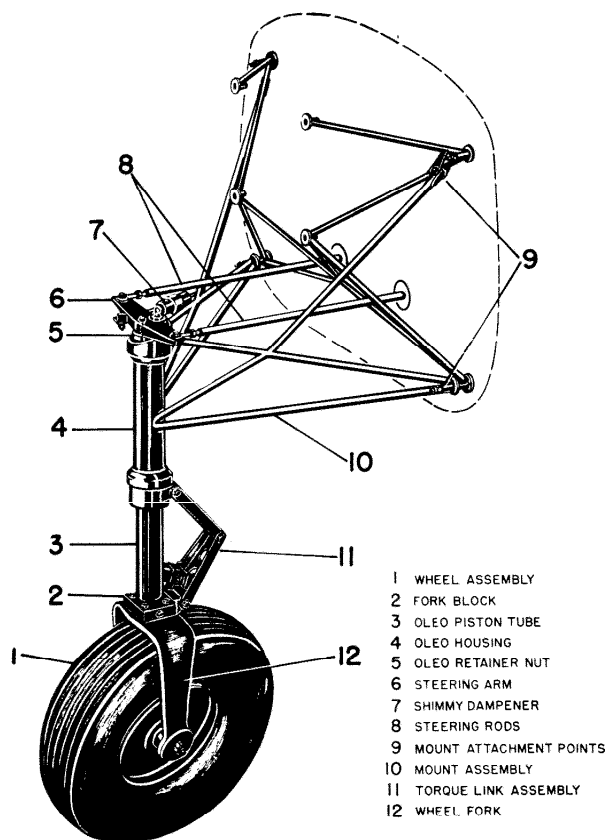

NOSE WHEEL INSTALLATION

Figure 16

3. Detach steering rods from nose wheel steering arms at top of strut.

4. Remove nuts from lower motor mount bolts, on firewall, and drive the bolts back to the motor mount bushings, being careful not to drive the bolts completely through the bushings as all the engine weight will be applied to upper motor mount attachments, causing damage to the mount. Then remove bolts from upper attachment of nose wheel mount to motor mount.

5. Slide nose wheel unit forward and down to clear it of motor mount.

The nose wheel shock absorbing unit is an oleo-pneumatic strut in which the air operating under pressure serves as the taxiing shock absorber, while the oil absorbs the major loads. The entire oleo can be detached from the nose wheel mount as follows: (See Figure 16).

1. After detaching bottom cowl, unsafety the oleo retainer nut on top of unit, and remove cap screw in top of steering arm assembly.

2. Remove through bolt from steering arm assembly and detach assembly.

3. Insert screw driver in slot in retainer nut and hold screw driver against the oleo housing to prevent the nut from turning.

4. Rotate oleo unit by turning nose wheel to unscrew the unit from the retainer nut. When the nut is free the oleo may be removed from its housing.

Replacement of the oleo is done by reversing this procedure. A dust shield is located on top of the upper bearing and should be properly in place there after the oleo is reinstalled. At this time the sealing of the bearings should also be checked, and the retainer nut pulled down to the proper position. To get a snug fit of the oleo strut on the bearings, pull the nut up tight, then back it off enough so that the oleo can be rotated freely but has no play.

The chrome-plated oleo piston tube is removed in order to replace seals, which consist of 2 "O" rings and a rubber wiper strip, located on the bearing block assembly. The oleo unit can be disassembled with the nose wheel housing and the outer tube of the oleo strut in place on the airplane as follows:

1. Let air escape from air valve at top of unit, then remove valve core.

2. Detach lower end of oleo torque link assembly from fork block.

- | | |
|-----------------------------------|---------------------|
| 1 WHEEL ASSEMBLY | 16 BEARING BLOCK |
| 2 FORK BLOCK | 17 OUTER "O" RING |
| 3 OLEO PISTON TUBE | 18 UPPER SNAP RING |
| 4 OLEO HOUSING | 19 OUTER OLEO TUBE |
| 5 OLEO RETAINER NUT | 20 AIR VALVE GASKET |
| 11 TORQUE LINK ASSEMBLY | 21 AIR VALVE |
| 12 WHEEL FORK | 22 LOWER BEARING |
| 13 LOWER SNAP RING | 23 UPPER BEARING |
| 14 WIPER STRIP | 24 DUST SHIELD |
| 15 INNER "O" RING & BACKUP WASHER | |

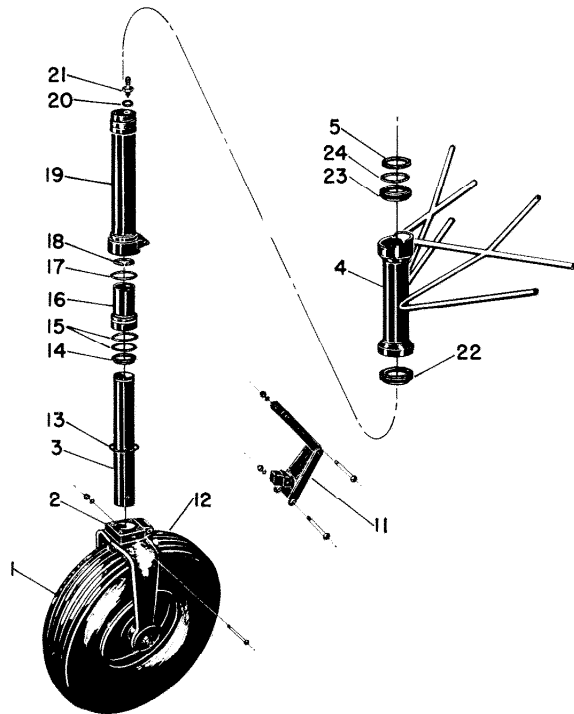

NOSE WHEEL OLEO BREAK-DOWN

Figure 17

3. Remove lower snap ring, located inside and at bottom of outer oleo strut tube, with small nosed pliers.

4. Slide piston tube and bearing block assembly out of outer tube. Oleo fluid will flow from the outer tube and much of it can be caught in a container and reused.

5. Remove upper snap ring on piston tube.

6. Slide bearing block off top of piston tube, taking precaution not to damage "O" rings in the process.

To reassemble the oleo unit, reverse this procedure, being very careful to see that the snap rings are properly reinstalled.

No. 40 Univis petroleum base hydraulic oil is used in the nose oleo. To add oil to the unit, first release all the air through the air valve, allowing the oleo to compress fully. Next remove the air valve core and fill the unit through this opening, extending the strut slowly while adding fluid. Compress the oleo again to within 1/4" of full compression, allowing excess oil to overflow and working out any trapped air. Then reinsert the air valve and pump up the strut.

The nose wheel oleo strut of the Tri-Pacer is properly extended when 3 1/2 inches of the chrome plated tube is exposed with the plane in normal ground altitude at normal light weight (no occupants or baggage). This dimension is controlled by changing the air pressure in the unit.

To add air to the nose gear, first unfasten the right side of the bottom engine cowl. Unscrew the air valve cap on top of the oleo unit and attach a high capacity air hose or pump. Increase the air pressure in the oleo until five or six inches of the chrome strut is exposed. Then release air from the valve in short spurts until the 3 1/2" dimension is obtained. Rock the airplane longitudinally, working the nose wheel oleo to make sure of proper extension after normal operation.

Shimmy of the steerable nose wheel is controlled by means of a shimmy dampener which is attached to the right side of the nose wheel mount. This dampener should require no servicing other than routine inspection during periodic checks. In case of damage or malfunctioning, the dampener should be replaced rather than repaired. In installation of the dampener, vertical alignment of the piston rod with nose wheel steering arm must be maintained to prevent binding of the rod during its full travel.

If found to need additional oil, the dampener can be filled with Univas No. 40 as follows:

1. Remove unit from its attachment.
2. Remove cotter pin from end of piston rod.
3. Slide piston rod forward as far as possible until aft end is completely inside cylinder.
4. Refill with hydraulic oil, making sure that all air is excluded from the cylinder.
5. Push piston rod back in place, replace cotter pin and then replace unit.

Steering of the nose wheel is affected by use of the rudder pedals which actuate steering rods connected to steering arms at the top of the nose wheel unit. The length of the steering rods can be adjusted at either end by turning in or out threaded eye bolts. Adjustment is normally accomplished at the forward end of the rods, and should be done in such a way that the nose wheel is in line with the fore and aft axis of the plane when the rudder pedals and the rudder are centered. Alignment of the nose wheel can be checked by pushing the airplane back and forth with the rudder centered to determine that the plane follows a perfectly straight line. Turning arc of the nose wheel is 20 degrees in each direction and is adjusted at stops on the steering arm.

VI. FUEL REQUIREMENTS:

Aviation Grade 80-87 octane gasoline should be used in the Tri-Pacer.

The tank and line sumps should be drained regularly to remove water or sediment.

The oil capacity of the Lycoming O-320 is 8 quarts. It is recommended that engine oil be changed every 50 flying hours or sooner under unfavorable conditions. The minimum safe quantity of oil required is 2 quarts. The following grades are recommended for the specified temperatures:

Temperatures above 40° F _____ S. A. E. 50

Temperatures 10° below 40° F _____ S. A. E. 30

VII. CARE OF WINDSHIELD AND WINDOWS:

The windshield and windows are made of plexiglas and a certain amount of care is required to keep them clean and clear. The following procedure is suggested:

1. Flush with clean water and dislodge excess dirt, mud, etc., with your hand.
2. Wash with mild soap and warm water. Use a soft cloth or sponge (Do not rub.).
3. Remove oil, grease or sealing compounds with a cloth soaked in kerosene.
4. After cleaning, apply a thin coat of hard polishing wax. Rub lightly with soft dry cloth.
5. A severe scratch or mar can be removed by using jewelers rouge to rub out scratch, smooth on both sides and apply wax.

SECTION FOUR

INSPECTION INSTRUCTIONS

ENGINE SECTION

ITEM 1—ENGINE OPERATION:

- Run engine to minimum 120° oil temperature—check full throttle static R.P.M. both magnetos.
- Check magnetos 100 R.P.M. drop at 1800.
- Check carburetor heat 100 R.P.M. drop at full throttle.
- Check ignition switch for operation.
- Check idle R.P.M. 550-600 carburetor heat-off.
- Oil pressure (minimum idle 25. Normal 65-85).
- Master switch on check generator and voltage regulator for operation.
- Battery fully charged will show very slight indication on Ammeter at full throttle.
- Check idle cut-off at 800 R.P.M. Engine should cut off clean.

Lycoming O-320 *Maximum R.P.M. 2700*
Static R.P.M. Metal Fixed Pitch ----- 2270-2480

ITEM 2—ENGINE MOUNT AND ATTACHMENTS:

- Check engine mount for damage and cracks at gussets or in corners.
- Inspect protective finish on mount; sand and touch up bare areas.
- Inspect rubber shock mounts for rubber deterioration and tension.
- Engine mount bolts should be tightened to 60 to 80 inch pounds.
- Check mount bolts for safety.

ITEM 3—COWLING AND BAFFLES:

- Clean and inspect engine cowling for dents and cracks at hinges and reinforcement.
- Check for tension adjustment on cowl doors at latch.
- Tension prevents vibration and cowl cracking.
- Check baffles for cracks and felt installation to prevent chafing.

ITEM 4—MAGNETOS, WIRING AND SHIELDING:

- Check magneto for secure attachment.
- Check breaker point housing for excessive oil.
- Check points for gap and pitting. Gap setting .012".
- Check plug wiring connections at magneto and wire insulation for deterioration and chafing.
- Check for grommets at baffles.

ITEM 5—OIL DRAIN AND SAFETY PLUG:

- Drain oil and check for metal particles.
- Remove, clean and check oil screen for metal particles.
- Change oil filter if installed and check flexible lines for deterioration.

SECTION FOUR

ITEM 6—OIL RADIATOR:

- Inspect oil radiator for evidence of leaks and chafing around baffles.
- Check lines for deterioration and chafing.
- Check core for clear air passage.

ITEM 7—SPARK PLUG SERVICE:

- Remove plugs, bomb blast and clean.
- Plugs with badly burned electrodes should be replaced.
- Reset gap to .025".
- Reinstall using thread lubricant to prevent seizing and torque to 300 to 360 inch pounds or 30 foot pounds.

ITEM 8—STARTER:

- Check starter motor for mounting security.
- Check commutator for excessive wear and bridging.
- Inspect wiring insulation for deterioration and connections.
- Check ring gear for damaged teeth and nose cowl clearance.
- Check starter shaft bushings for play.
- Check brush retention and tension springs.

ITEM 9—GENERATOR AND WIRING:

- Check generator mounting for security.
- Check brush retention and condition of tension springs.
- Replace worn brushes before there is any danger of brush failure.
- Brush worn over 3/16 of an inch should be replaced.
- Check generator drive belt for 3/4" hand deflection.

ITEM 10—CARBURETOR AND HEATER:

- Check carburetor for mounting security.
- Inspect carburetor bowl for cracks, particularly at inlet.
- Drain carburetor float chamber and check inlet finger screen-resafety.
- Operate throttle in cockpit to be sure that throttle arm hits stops in open and closed positions without binding or sticking.
- Check operation of mixture control for binding or sticking and full rich position.
- Inspect carburetor air box for security and cracks—heater valve for full travel.
- Check rubber intake hose connections for deterioration and clamp security.
- Check intake system for leaks and cracks.
- Clean air filter in kerosene and saturate with No. 10 oil and allow to drain before installation.

ITEM 11—FUEL LINES AND STRAINER:

- Check fuel lines for leaks and hose deterioration.
- Check hose supports for security and chafing.
- Drain and clean fuel strainer and resafety.
- Check for stains around fuel system indicating leaks.
- Check all connections for tightness.

ITEM 12—EXHAUST STACK AND MUFFLER:

Check stack flanges for security, cracks and leaks.
 Remove all heater and muffler shrouds and inspect for corrosion, cracks and leaks that might transfer gas to the cockpit, particularly through the cabin heater system.
 Check tailpipe, muffler and stacks for security at all clamps and slip joints.
 Check cabin heater box and control valve for operation.
 Check cabin and carburetor heat flexible tubing for security and general condition.

ITEM 13—ENGINE CONTROLS AND FIREWALL:

Check firewall for open holes and gas leaks from engine compartment.
 Check all controls for grommets and sealing putty.

PROPELLER SECTION

ITEM 14—PROPELLER:

Remove spinner and check for cracks or dents in spinner and back plate.
 Check propeller for excessive dents or irregularities.
 Metal propeller hub bolts are to torque from 350 to 375 inch pounds.

ITEM 15—PROPELLER OPERATION:

Check operation and limitations sheet No. 58 furnished with each Aeromatic Model F200-H Propeller for proper operation.
 Comply with instructions furnished covering installation of Aeromatic Model F200-H Propeller with Hydro-actuated control.

ITEM 16—GOVERNOR AND CONTROLS:

Governor and controls. Follow Propeller Manufacturer's instructions.

COCKPIT, PASSENGER AND CARGO SECTION

ITEM 17—SEATS:

Check rear seat canvas for adjustment and deterioration.
 Check front seat fore and aft adjustment and lubricate track.
 Check condition of safety belts and operation of buckles.

ITEM 18—WINDSHIELD:

Check weatherstripping for security in channels and for weather leaks.
 Visual check for cracks, crazing, distortion and discoloration.

ITEM 19—POWER PLANT INSTRUMENTS:

Check power plant instruments for mounting security.
 Check connections and plugs.
 Check placards and limitation markings.

Lycoming O-320 Series Engine:

Tach.:
 Red Line ----- 2700 R.P.M.
 Green Arc ----- 500—2700 R.P.M.
 Oil Pressure:
 (Same as O-235 Series Engine). See Above. 65 to 85 lbs.
 Oil Temperature:
 Red Line ----- 245°
 Yellow Arc ----- 40°—120°
 Green Arc ----- 120°—245°

ITEM 20—FLIGHT INSTRUMENTS:

Check flight instruments for mounting security.
 Check connections and plugs.
 Check placards and limitation markings.
 Air Speed:
 Red Line ----- 170 M.P.H.
 Yellow Arc ----- 135-170 M.P.H.
 Green Arc ----- 53-135 M.P.H.
 Flaps Extended
 White Arc ----- 49-95 M.P.H.

ITEM 21—SWITCHES, LIGHTS-FUSES:

Check battery cable connections for security.
 Check panel on left side to read, "Circuit Breakers under panel."
 Check circuit breaker wire connectors for security and insulating sleeves.
 Check position and landing light switches on panel for placards and operation—green, right wing—red, left wing and white, tail light.
 Check cockpit lights for operation and rheostat for dimming action.
 A circuit breaker will be used on all circuits except the Stall Warning Indicator.

ITEM 22—INTERIOR TRIM:

Check cockpit post fairings and all metal trim for security.
 Check control column boot and pulley covers for security.
 Check floor mat for attachment.

ITEM 23—DOOR LATCH AND HINGES:

Check door hinge and rivets for looseness.
 Check door latch plunger for complete extension to prevent doors opening while taxiing.
 Check door for improper fit or damage resulting in air leaks.

ITEM 24—ENGINE CONTROLS:

Check mixture control for panel placard and operation for smoothness.
Check carburetor heat for panel placard and smoothness of operation.
Check throttle for smooth operation and operation of friction lock.
Check primer for operation and leaks behind the panel.
Check cabin heat for panel placard and full travel of heater butterfly valve.
Check rear seat heater and under floor tube for possible interference with controls and control cables.
Check ignition switch for panel and terminal security.
Check for placard. Off, Left, Right and Both.

ITEM 25—CONTROL COLUMN AND ATTACHMENTS:

Check under floor extension of control column.
Check column mounting bearings.
Check fork in connector tube for wear and play.
Check control column pulleys for wear and alignment.
Check turnbuckles for safety—maximum three (3) threads showing.
Check Universal Joints for excessive wear.
Check fiber guides forward of panel for wear, also shaft bearings in panel.

ITEM 26—RUDDER PEDALS AND LINKAGE:

Check rudder pedal assembly for play and travel freedom.
Lubricate hinges and torque tube bearings and check for safety.
Check rudder pedal return springs for attachment.

ITEM 27—FLAP CONTROLS:

Check flap handle for placard and condition of ratchet for two flap positions.
Check flap cable and pulley through inspection opening on under side of fuselage.
Remove fuselage belly access door and check flap pulleys at top and bottom of fuselage.
Through the zipper opening in the top upholstery check the two flap cable pulleys and turnbuckles—maximum three (3) threads showing.
Remove rear wing butt fairings and check cable fairleads.
Through wing inspection openings check the attachment of flap return springs.

ITEM 28—CABLES AND PULLEYS:

Check all cables for broken strands.
Remove butt fairings and check top deck aileron pulleys for wear and security.
Check aileron pulleys at both ends of panel.
Remove covers and check pulleys—front floorboards.

ITEM 29—FLIGHT CONTROL OPERATIONS:

Check aileron, rudder and elevator controls from cockpit for smooth operation.
Check wheel or stick for neutral position with controls surfaces streamlined.

ITEM 30—TRIM TAB CONTROLS:

Check stabilizer trim control for smooth operation.
Check indicator against stabilizer for proper position.

ITEM 31—FUEL SELECTOR VALVE:

Check fuel valve for smooth operation.
Check placard for "On" and "Off" positions.
Check valve for leaks.

LANDING GEAR

ITEM 32—SHOCK STRUTS:

Check shock cords for deterioration and hydraulic unit for operation.
When worn out this sealed unit must be replaced.
Check nose oleo unit for operation, leaks and looseness.

ITEM 33—AXLES AND WHEELS:

Remove wheels, wash, check and relubricate bearings.
Check brake shoes for wear and drums for scoring.
Check brake expander tube for leaks.
Install wheel and axle nut only tight enough to remove end play.

ITEM 34—TIRES AND FAIRINGS:

Check tires for 22 pounds of air pressure in main wheels, 15 lbs. in nose wheel (PA-22). PA-20 main wheels 20 lbs.
Replace tires that have cord showing.
Check gear fairings for security and chafing.

ITEM 35—BRAKES AND OPERATION:

Check brake reservoirs for fluid and assembly for leaks.
Check operation and holding ability of parking brake.

ITEM 36—LANDING GEAR:

Hoist aircraft and check gear bushings, vee bushings are replaceable if worn.
Check for skin wrinkles indicative of inside damage.

ITEM 37—TAIL WHEEL:

Check tail wheel and spring assembly for looseness.
Check condition of tail spring pad.
Remove wheel, wash and repack bearing.

FUSELAGE

ITEM 38—FABRIC CONDITION:

Check condition of fabric with the eraser end of a pencil, particularly on top surfaces.

Check the finish for cracks or checks. Sand out and repaint all checks or cracks to preserve the fabrics.

ITEM 39—WING FITTINGS:

With wing root fairings removed inspect wing fittings with a flashlight and magnifying glass for minute cracks in the ears.

Check bolts to be sure there are no threads in bearing and bolts are properly safetied.

Check wing fitting holes for elongation by having some one pull up and down on the wing tips.

ITEM 40—LANDING GEAR FITTINGS:

Remove both landing gear fairings and inspect all fittings with flashlight and magnifying glass for signs of cracks or hole elongation.

ITEM 41—FUSELAGE STRUCTURE:

Through inspection openings and through the baggage compartment cover check the condition of all tubing for rust, damage and protective coating.

Check all wood stringers for damage and security.

ITEM 42—DEBRIS ACCUMULATION:

Check the bottom of the fuselage and fabric under floor boards for bolts, nuts and other objects that might jam controls or pulleys.

Check the rear of fuselage for open drain grommet.

If considerable dirt or oil exist on the fuselage bottom, use a non-caustic soap and wash out the dirt to prevent fabric rot.

ITEM 43—CONTROL CABLES AND PULLEYS:

Check for broken control cable strands by sliding a cloth over the cable in vicinity of fairleads.

Check upper and lower elevator turnbuckles for safety and maximum of three threads showing outside of barrel.

Check bungee spring attachment at elevator horns and both pulleys at stabilizer yoke for wear and safety.

Check four rudder cable fairleads and cables for wear aft of baggage compartment.

Check four rudder pulleys on cockpit floor for wear and safety and check condition of pulley covers.

ITEM 44—FAIRINGS:

Check tail assembly fairings for cracks and missing metal screws.

WINGS, AILERONS AND FLAPS

ITEM 45—WING-FABRIC:

Check left and right wing fabric for holes, cracks or checks in the finish and open drain grommets at each rib bay trailing edge. (Fabric usually deteriorates on the upper surface of the wing or along the trailing edge.)

Install inspection grommets at drag wire fittings to inspect drag wires for tension and wing ribs and compression members for damage.

ITEM 46—STRUTS-LIFT:

Check right and left wing strut fittings for elongation by having some one lift up and down on the wing.

Check bolts for fitting attachment to the spar.

Check struts for dents or cracks, also sight down strut trailing edge to ascertain that struts are straight.

Check strut end forks and fork lock nut. The maximum number of threads allowed outside the strut end is fifteen.

ITEM 47—WING BOLTS:

Check strut attachment bolts to be sure there are no threads in bearing and bolts are properly safetied.

ITEM 48—AILERONS:

Check both ailerons for wrinkles which are possible signs of structural damage.

Check each rib bay for an open drain grommet.

Check condition of fabric and finish, refinishing any dope cracks, checks, or ringworm.

ITEM 49—AILERON HINGES:

Check aileron hinge legs for security at rear spar and false spar.

Check hinge pins for wear and safety. Worn or loose pins must be replaced.

ITEM 50—AILERON CONTROLS:

Remove inspection covers and check the two cables in each wing for interference and chafing.

Check the two pulleys in each wing for condition, wear and safety and lubricate pulley bearings.

Check wear and safety of the two fairleads in each wing.

15° up 15° down +/- 2°.

Stops are installed on center hinge and on control column.

Stop at aileron should engage first to allow for full travel of ailerons.

Check the four aileron horn bolts for wear, threads in bearing and safety.

Check the two turnbuckles in left wing and one turnbuckle and shackle

connector in the right wing. Turnbuckles safetied and no more than

three threads showing outside the barrel.

To locate broken strands at fairleads or pulleys slide a cloth over the

cable, all cables with broken strands are to be replaced.

ITEM 51—FLAPS:

- Check fabric condition of both flaps with a pencil eraser end for deterioration.
- Check condition of finish for cracks, checks, or ringworm and refinish any that exist.
- Any internal structural damage will cause wrinkles on the fabric surface.

ITEM 52—FLAP ATTACHMENTS:

- Each flap has two hinges and two hinge legs that are riveted to the wing false spar and attached with a single bolt to the wing rear spar.
- Lowering the flaps at over 80 M.P.H. can cause possible damage to these hinge legs so a careful inspection is recommended. Check stop in up position for streamline of flap.
- Check the hinge pins for wear and installation of washers and safety.

ITEM 53—FLAP MECHANISM:

- Check fafnir rod end bearings and push pull tube for clearance through hole drilled in the fafnir bearing rod to check minimum distance the push pull tube is screwed in the fafnir rod. Be sure lock nut is tight.
- Ascertain through inspection that both flap return springs are secure and in good condition. Operate flaps and check springs to be sure they do not chafe, bind or interfere with other controls of adjacent structure.
- Check travel:
 - Full Flap 40 +/- 2°.
- Check bellcrank casting for cracks, particularly at the ears and for safety and security of the bracket.

ITEM 54—WING ROOT FAIRINGS:

- Check left and right top wing root fairings for tension, adjustable through a hole at the trailing edge.
- Check all metal screws for security and the fairing for cracks.

EMPENNAGE

ITEM 55—STABILIZER:

- Check stabilizer fabric condition and drain grommets for restrictions.
- Check stabilizer rear hanger tube and front link tube for hinging action. Small holes are drilled in the fuselage tube and stabilizer link tube to drop oil in for lubrication. Lubrication of these tubes is very important and often neglected, resulting in the tubes freezing up.
- Lift up and down on the stabilizer checking for excessive play in the stabilizer yoke screw. The nut on the ~~bottom~~ ^{TOP} of the screw pulley will take up play if excessive.
- Check stabilizer yoke casting for cracks and link tube ears for worn bolts and safety.

ITEM 56—FIN:

- Inspect vertical fin for fabric condition and finish.
- Check for wrinkles, dents and signs of internal damage.

ITEM 57—RUDDER:

- Inspect fabric cover on the rudder for fabric and dope condition.
- Check bottom of rudder for an open drain grommet.
- Check rudder for alignment and possible internal damage usually indicated by a wrinkle in the fabric.
- Inspect rudder hinge pins for wear and safety.
- Check hinge bushings for play, these bushings are pressed in and should be replaced when worn.
- Check rudder stops to ascertain full travel:
 - 16° Right and 16° Left +/- 2°.

ITEM 58—ELEVATORS:

- Check fabric condition and finish on the elevators.
- Check for open drain grommets along the elevator trailing edge.
- Sight one elevator against the other for alignment.
- Check hinge pins and bushings for wear and replace any worn pins or bushings.
- Check elevator cable horns for safety, worn bolts and clearance in travel.
- Check elevator stops to ascertain full travel:
 - 24° up—12° down +/- 2°.

ITEM 59—EXTERNAL BRACING:

- Check empennage rigging wires for corrosion and cracks or nicks that might result in failure.
- Check fittings for alignment with the wire and bolts for safety.
- Rigging wires should be taut with little hand deflection.
- Check each wire to be sure there are no loose fork lock nuts.

ITEM 60—RUDDER AND ELEVATOR CONTROLS:

- Check rudder and elevator horns for worn bolts and safety with no threads in bearing.
- Check horns for alignment with the cable and freedom of travel.
- Check top and bottom cable turnbuckles for safety and a maximum of three threads showing outside the barrel.
- Sight the cables through the fuselage for interference and chafing.

ITEM 61—ELECTRICAL SYSTEM:

- Check wiring for chafing, clamping.
- All terminals tight.
- Bonding straps secure.
- Landing lights—mounting and operation.
- Navigation lights—mounting and operation.
- Battery installation—terminals secure. Charged, acid spillage.
- Radio installation for security and operation.
- Safe Flight Indicator for operation.
- Circuit breakers or fuses for security.

ITEM 62—FLOATS OR SKIDS:

Sight check rigging.
All brace wires tight and safetied.
Water ballast, if carried.
No leaks in floats. Structure OK.

ITEM 63—

All C. A. A. Mandatory Bulletins complied with.

Note: All the information in Inspection Instructions, along with a check list for 25-50 and 100 hour inspections can be obtained in special form from the Piper Aircraft Corporation.

SECTION FIVE

WARRANTY

Piper Aircraft Corporation hereby warrants each new airplane and part manufactured by it to be free from defects in material and workmanship under normal use and service, its obligation under this warranty being limited to making good at its factory any part or parts thereof which shall, within ninety (90) days after delivery of such airplane or part to the original purchaser or fifty (50) hours of operation, whichever shall first occur, be returned to it with transportation charges prepaid and which its examination shall disclose to its satisfaction to have been defective. No other warranty shall be implied by law or otherwise, and no other or further obligation or liability shall be incurred by Piper Aircraft Corporation by reason of the sale of any airplane or part thereof or its use whether for breach of warranty (expressed or implied by law, or otherwise) or negligence in manufacture, or otherwise. Upon the expiration of the period above stated, any such obligation or liability shall terminate. In no event shall Piper Aircraft Corporation be liable for special or consequential damages. No distributor, dealer, agent, or employee of Piper Aircraft Corporation is authorized to extend any other or further warranty, or incur any additional obligation, in its behalf in connection with the sale of its products.

This warranty shall not apply to any airplane or part manufactured by Piper Aircraft Corporation which shall have been repaired or altered outside of its factory, or which has been subject to misuse, negligence or accident.

Piper Aircraft Corporation makes no warranty whatever with respect to engines, wheels, propellers, ignition apparatus, starting devices, generators, batteries, instruments or other trade accessories, inasmuch as they are usually warranted separately by their respective manufacturers.

PIPER AIRCRAFT CORPORATION.